

advance **AUTO-WIRE**

**INSTALLATION INSTRUCTIONS
FOR CUSTOM WIRING PANEL FOR
1969 - 1972 TRIUMPH TR6
(with overdrive relay)**

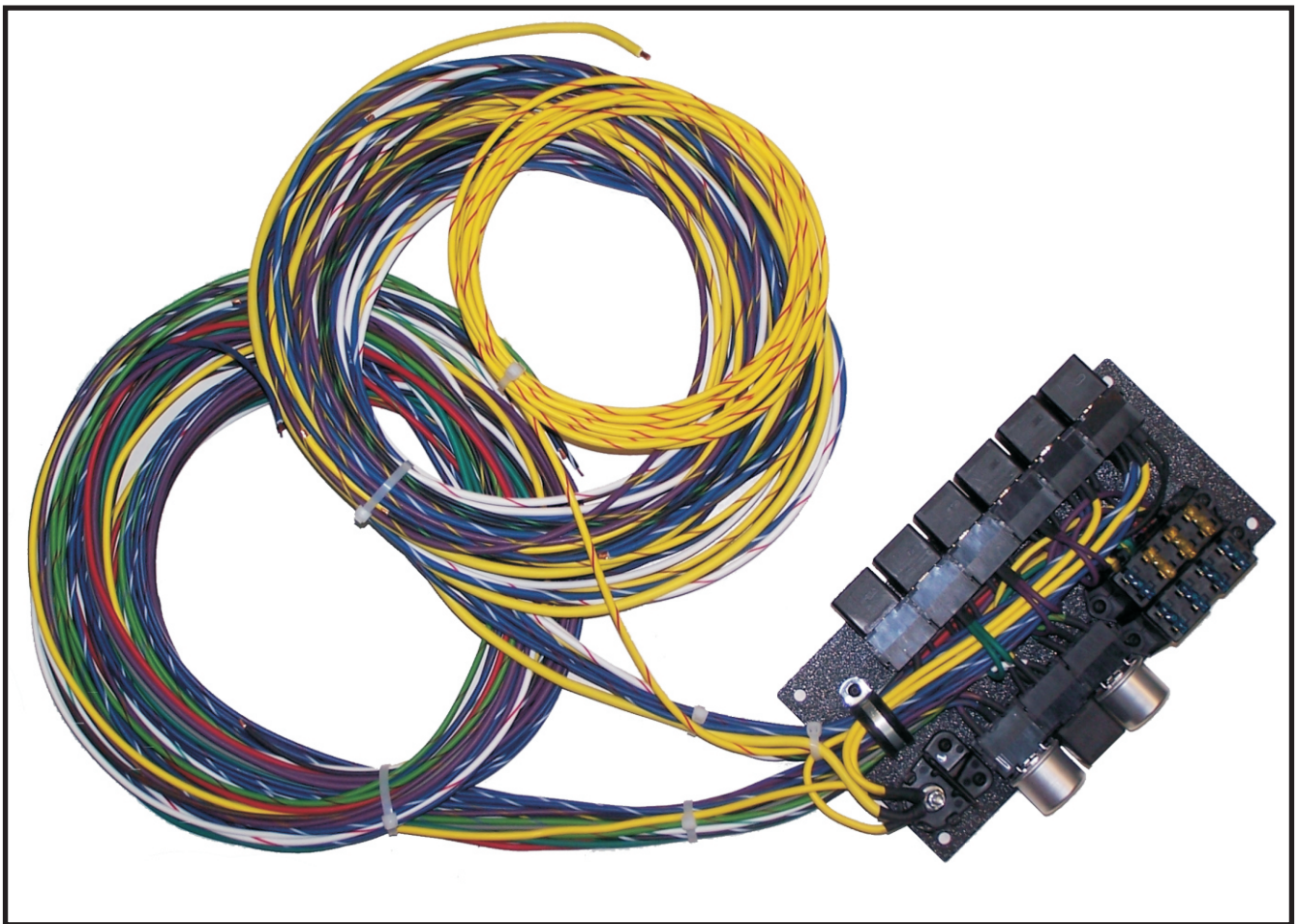

By Dan Masters





Copyright © 2004, Dan Masters
ALL RIGHTS RESERVED

No part of this manual may be reproduced in any form,
except for the inclusion of brief quotations in reviews,
without permission in writing from the author or publisher.

WARRANTY: Advance Auto Wire warrants the wiring system described in and sold in conjunction with this manual to be free from manufacturing defects for a period of one year from the date of purchase, or, if installed by a professional installer, for one year from date of delivery to the owner, not to exceed two years from date of purchase. Advance Auto Wire will repair or replace the wiring system, at our option, in the event of a defect. A return authorization is required before the wiring system will be accepted for warranty service. This warranty applies to the original owner, and is not transferable. This wiring panel is to be purchased, installed, and used only by those with the requisite knowledge and experience to properly evaluate the design, material, and construction for suitability, and to properly install the panel and associated wiring. Advance Auto Wire is not responsible for mechanical or electrical damage or personal injury directly or indirectly resulting from the installation and usage of this panel. The purchaser and/or installer of this panel assumes all responsibility for any and all damages that may result, directly or indirectly, from the installation of this panel. In any circumstance, the liability of Advance Auto Wire shall be limited to the original purchase price of the wiring system. Installation of this panel and associated wiring constitutes acceptance of these terms.

CUSTOM WIRING PANEL

Installation instructions

CAVEAT: *Installation of this wiring kit requires a minimum amount of familiarity with electrical circuits and construction techniques. If you have any doubt about your ability, it is strongly recommended that you enlist the aid of a friend with the requisite experience. Because so much of the success of this kit depends on the ability of the installer, it is recommended further that some time be spent perusing the various automotive electrical books available from your public library or other source. Before beginning installation, please read these instructions thoroughly. If you run into problems, tech support is available, either by e-mail or phone. See page 10 for contact info.*

CIRCUIT DESCRIPTIONS:

For the most part, the individual circuits are straight forward, but some of them need further explanation.

Fuel pump circuit: The relay for the fuel pump is operated whenever the ignition key is on, but it has a couple of safety features. Although an inertia switch is not included with this kit, it is strongly recommended that one is installed. The inertia switch will open whenever the car is subjected to a hard jolt, such as in an accident, preventing fuel spillage if a fuel line should be ruptured. In the excitement following a serious accident, it is very easy to forget to turn off the ignition switch. Without the inertia switch, several gallons of raw gasoline might be dumped onto the ground, just waiting for a careless person to walk by with a lit cigarette! This switch may be purchased from Moss Motors for about \$50.00, or you may scrounge through your local junkyard and get one from a late model fuel injected car for a lot less (that's the reason one isn't included in the kit).

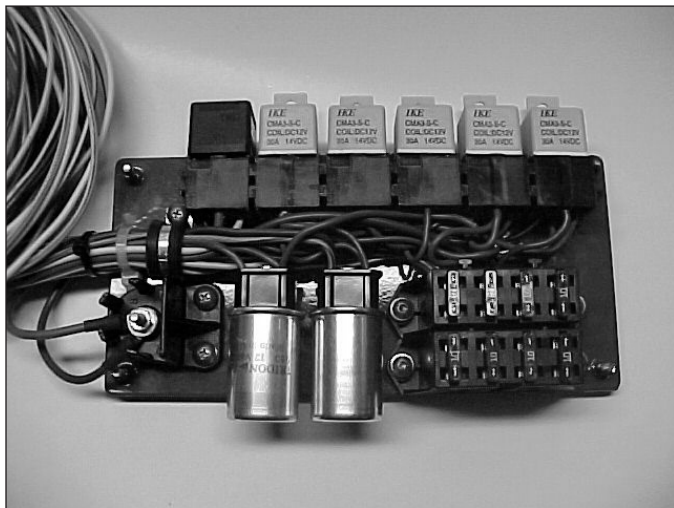

Completed Power Block, ready for installation in a TR3. The wiring is coiled up, waiting to be routed as appropriate.

The cutoff switch (optional) provides for a small bit of theft protection. This switch should be hidden from view, but easily accessible. If this switch is open, the pump will not operate, and the engine will die in a very short distance when the fuel in the float chambers is exhausted, leaving the thief stranded in the middle of the street. To prevent embarrassment to yourself if you should forget to turn the switch back on before starting your car,

the normally closed contact of the relay sends power to the warning buzzer. Additionally, if the inertia switch should actuate from a hitting a pothole or such, the buzzer will sound, reminding you to reset the switch before your car comes to a stop from lack of gas.



Power Block as installed in a TR3. In this car, the best location for the block was under the battery box, behind the dash, but a suitable location can be found in any car.

Headlight fuses: If you'll notice, there are none! I am **STRONGLY** opposed to the use of fuses in the headlight circuit. Having the headlights go out while doing some spirited driving on winding back road on a moonless night because a wire momentarily bounced into contact with ground can be **fatal!** Having your car burn is only a financial loss. Some might disagree with me, but the choice is clear in my mind.

Hazard switch: Do yourself a favor and discard the stock hazard switch. The majority of turn signal problems are due to faulty hazard switches. Replace it with the DPDT (double pole, double throw) switch supplied (or similar if you want to put the switch where it can be seen and don't like the looks of the one supplied), and wire it as shown on the wiring diagram. Just be sure **NOT** to get one with a "center off" position, as neither the turn signals nor the hazard flasher will work with the switch in the off position.

Cooling fan: The cooling fan is wired to run even if the ignition is off. When an engine is shut off, the temperature of the water often rises quite sharply for a few minutes. This can lead to starting problems if a restart is attempted shortly after the engine was shutdown but before the temperature can fall again. The schematic diagram shows an optional ON-AUTO switch that may be desired (not supplied - you'll want to choose one that matches your dash decor). In the ON position, the fan will run all the time, hot or not, ignition on or off. This feature can be useful if you should find yourself in a traffic jam on a hot summer day. By manually starting the fan before the temperature rises, you maybe able to prevent overheating. It is much easier to keep the temperature down than it is to bring it back down after it has risen.

Another option you may want to consider is an ON-OFF-AUTO switch, as shown on page 9. This switch provides the option of ensuring that the fan does NOT run under certain situations. For

example, when you are working on the car under the hood, and you don't want to run the risk of injury from the fan starting unexpectedly, the ON-OFF-AUTO switch can be placed in the OFF position and the fan won't run, regardless of temperature (be sure to place the switch back in the ON or the AUTO position before driving the car to prevent the possibility of overheating). In the AUTO position, the fan will run only if the thermostat calls for it. When the temperature falls back to normal, the fan will shut off. In this situation, the fan will usually only run when the car is being driven at low speeds.

An output from the fan relay is provided to operate an indicator lamp to give a visual indication that the fan is running. This lamp is optional and is not provided as part of the kit. This lamp should be mounted on the dash in clear view, so you should choose one that is compatible with your particular dash layout, whether you are using the stock dash, gauges, and switches, or aftermarket units. You may find that this lamp glows with the fan off while you are driving at high speeds, as the fan may spin from the wind rushing through the radiator. In this case, the fan motor acts as a generator, driving the lamp. For this reason, you may prefer not to use the lamp. In that case, just tie the light green/red wire up out of the way, insulating it so that the bare end doesn't come into contact with ground.

Power relay: The sole purpose of this 40 amp, 4-pin SPST relay is to take the load off the ignition switch. Using the relay, however, gives an opportunity to add a modest theft protection as well. By wiring the relay coil ground connection through a simple ON-OFF switch, the ignition circuit can be rendered inoperable by opening the cutout switch. If you prefer not to use the switch, wire the black/white wire directly to a good ground.

Relays: Standard 5-terminal SPST automotive type relays are required for the headlight and the cooling fan relays. The difference between a 5-terminal and a 4-terminal SPST relay is that with a 5-terminal relay there are *TWO* output terminals, both having an "87" designation. The horn and overdrive circuits only require 4-terminal SPST relays. If you wish, you can use a 5-terminal relay for these circuits with no problems, but you must use a 5-terminal relay for the other functions. If you should use a 4-terminal relay for one of them, only half of the circuit will work. In an emergency, you could get by with this for the headlight circuits, but you would only have lights on one side of the car. Using a 4-terminal relay for the cooling fan would cause you to lose the indicator lamp function - not a big deal.

The relay *supplied* for the horn is a 5-terminal SPDT relay, the same as used for the fuel pump. In this application, the 87a terminal is not used, but if you should be on the road and the fuel pump relay should fail, you can pull the horn relay and use it for the fuel pump, allowing you to continue driving until you can get the correct replacement relay. Not having a horn during this time is not a serious problem. In a pinch, any of the relays supplied could be used for the power relay until you could get home and get a correct replacement for it.

Fuses: The fuses supplied with the panel have a built-in LED that lights when the fuse blows, making it easy to spot the trouble. These fuses cost more than the standard, but they are worth it. They can be found at many auto parts stores. When testing your wiring, you may want to substitute the cheaper standard fuses. Hopefully, you won't blow any!

Do not install fuses with a higher rating than those shown on the diagram unless you have done an evaluation and have determined that the wiring is capable of handling the higher current allowed by the larger fuse. This evaluation should include the capacity of the relays (30 amps maximum) as well as the current capacity of the wiring.

Alternator: It doesn't seem likely that anyone would go to the trouble of upgrading the wiring yet retain the old alternator so no provisions have been made in this kit for that purpose. As the least expensive, most readily available alternator is the GM SI series (#7127), a wiring harness with the connector already installed has been provided with the kit. Should you prefer another make, you will need to obtain the correct connectors for your choice.

Ammeter: As the stock ammeter is only rated for 30 amps, it is highly recommended that the stock ammeter not be utilized. If you really want an ammeter, an aftermarket unit, rated at least for 60 amps, should be used instead. Refer to the diagram on page 9 for wiring details. If, for whatever reason, you wish to retain the stock ammeter, and retain it as a functional unit, wire it as shown on page 9. If you do, two important cautions should be observed:

1. Should the alternator ever fail while in operation, all power will then be drawn from the battery. In this situation, all of the current will be routed through the ammeter and associated wiring, which may burn out the ammeter and/or overload the wiring.
2. Without the engine running, never operate enough electrical loads such that the ammeter registers over approximately 20-25 amps. As stated above, under this condition, all the current will now be drawn through the ammeter.
3. You may want to use the optional shunt, shown on page 9. With this shunt (12 ga wire), approximately half the charging current will be going through the shunt, and half through the ammeter. The ammeter will still work, but it will be inaccurate, by about half. Accuracy is not really important - only what the ammeter reads compared to normal.

Gauges: The wiring diagram shows connections for the original TR6 gauges. If you want to use after-market gauges, you will have to eliminate the gauge voltage stabilizer, as it is not needed. If you leave the stabilizer in the circuit, after-market gauges will pulsate, swinging from zero to the correct value rapidly. See page 11 for connections for these gauges.

PANEL WIRING CONNECTIONS:

The wiring panel (power block) is supplied pre-wired. Pre-terminated wires leaving or entering the power block are to be connected to the remainder of the wiring as described in the functional descriptions below:

Note: the first letter(s) below indicate the wire color code, and the following numeral (if any) indicates the wire gauge. Wire gauge designations are only shown where there are two or more wires leaving the panel of the same color. In this case, wire size is noted to help identify which wire is which.

Color codes:

<i>N</i>	<i>Brown</i>	<i>LG</i>	<i>Light Green</i>	<i>G</i>	<i>Green</i>
<i>U</i>	<i>Blue</i>	<i>W</i>	<i>White</i>	<i>B</i>	<i>Black</i>
<i>R</i>	<i>Red</i>	<i>Y</i>	<i>Yellow</i>	<i>K</i>	<i>Pink</i>
<i>P</i>	<i>Purple</i>	<i>S</i>	<i>Slate</i>	<i>O</i>	<i>Orange</i>

B: Ground connection.

BG: Connects to the switch for the cooling fan, and is grounded to operate the fan relay.

BW: Ground for the power relay. If you wish to use the anti-theft provision, run this wire to ground through a hidden switch.

BY: Grounded to operate the fuel pump relay. If you choose not to use an inertia switch or a cutout switch, this wire should be connected directly to ground.

G-14: Provides power to loads that are operable only when the key is on. Typically supplies power to the windshield wipers/washer, gauges, brake failure lamp, and low oil pressure lamp. Maximum load on this wire should be less than 4 amps.

G-12: Provides power to loads that are operable only when the key is on. Typically supplies power to the heater fan, brake lights, reverse lights. Maximum load on this wire should be less than 12 amps.

LG/P: Feeds the optional turn signal indicator lamp.

LG/N: Feeds the turn signals, and should be connected to the same color wire coming from the turn signal switch in the steering column. Maximum wattage for each TS bulbs should be 27 watts. (typically, #1157 bulbs)

LG/R: Power to the fan indicator lamp when the fan is on from the fan relay.

NR: Provides power to the headlight switch.

P: Provides power to loads that are operable with the key on or off. Typically supplies power to the “flash-to-pass” switch, clock, courtesy lamps, memory power for the radio, and power to the cigar lighter/accessory plug. Maximum load on this wire should be less than 15 amps.

PB: Grounded by the horn button, and operates the horn relay.

PN: Supplies the flasher voltage to the turn signal lamps, via the hazard switch.

PY: Supplies power to the horns when the horn relay is operated. The other side of the horns should be grounded. Maximum current on this wire should be no more than 15 amps.

R: Provides power to the parking/marker lights, and to the dash lights via the dash light dimmer.

RG: Power from the headlight switch to the fuse for the parking/marker and dash lights.

S: Input to the optional warning buzzer for the fuel pump relay. See text for details.

UN: Feeds the hazard warning indicator.

UR (8 foot): Power to the headlight low-beam relay from the dimmer switch.

UR (12 and 16 foot lengths): Power to the headlight low-beams from the headlight relay. Low beams should be a maximum of 120 watts each. One of these leads is longer than the other to

allow for crossing over from one side of the car to the other at the front of the car. It is assumed that both leads will be routed to the front of the car from the panel on the same side.

UW(two 8 foot lengths): One of these leads provides power to the headlight low-beam relay from the dimmer switch, and the other provides power to the high-beam indicator lamp. It doesn't matter which of these two leads is used for what, they are the same electrically speaking.

UW (12 and 16 foot lengths): Power to the headlight high-beams from the headlight relay. High beams should be a maximum of 120 watts each. Two lengths are provided for the same reason as for the low beams above.

W-14: Input to the ignition side of the alternator warning light from the power relay.

W-12: Provides power to the ignition system.

WG: Operates the ignition relay from the ignition switch.

Y-12: Provides power to the “BATT” terminal of the ignition switch.

Y-8: Main power feed from the alternator/battery. This wire carries *ALL* of the current used by the car.

YG: Operates the overdrive relay from the overdrive and the transmission switches

YN: Provides power to the cooling fan. Maximum load on this wire should be no more than 20 amps.

YP: Power to the overdrive solenoid from the overdrive relay.

YR: Supplies power to the fuel pump. Maximum load on this wire should be no more than 7 amps.

INSTALLATION DETAILS:

NOTE: Before proceeding with the installation of this panel and the associated wiring, remove the negative battery cable from the battery!

Panel: For ease of installation, all components are mounted on a flat panel. If you want, you can replace the panel with one of your own design, perhaps to better fit the area you plan to install the panel in. The panel components may be removed from the panel as long as you handle the wiring and components with care should you choose to make your own or to repaint the supplied panel to match your car.

The location of the flasher and relay sockets on the panel was deliberately planned to allow the flashers and relays to stick out from the panel so that they would be easy to grip when you need to replace them. In general, these components are a tight fit in the sockets, and a bit of force is needed to remove them - they can be hard to remove in tight quarters when you need to replace them. It helps to have “finger room” so you can get a good grip on them.

Location: The panel may be located anywhere you prefer, as long as certain criteria are satisfied. These criteria, in approximate order of importance, are:

1. The panel must be protected from the elements. Under the hood is OK, as long as the panel is mounted where water

cannot get to it during a rain or in a car wash. Inside the car is preferred.

2. The panel - and wiring - must be protected from physical damage. If you mount it inside the car, care must be taken to ensure that neither the panel nor the wiring is in an area where they might be struck by the passenger's or the driver's feet.

3. There must be room around the panel to route the wires to their proper destination without undue stress on the wiring, and there must be room to remove and re-install the relays.

4. Wire length must be accounted for. The leads coming from the panel and terminating in or around the dash are 8 feet in length. Eight feet is not all that long when you take into account that the wires have to follow the contours of the car's body, and do not make a straight run from the panel to the end device. A device mounted 2 feet from the panel may require 6 feet or more of wire to reach it.

5. Easy access to the panel for relay or fuse replacement is very desirable, but not mandatory. You shouldn't need to replace fuses or relays very often, so if you prefer to mount the panel in an inaccessible location, requiring removal of certain car components to get to it, go ahead and do so, knowing that you may regret it someday should you have to replace a fuse or a relay on the side of the road in the rain!

Mounting: Wherever you choose to mount the panel, it should have a flat surface large enough to hold the panel and the four screws used to mount it. Using the mounting template provided as a guide, center-punch and drill the four mounting holes, using a 1/4" drill bit. If you can't find a desirable place to mount the panel that is sufficiently flat, you can use unequal length spacers to compensate for the un-evenness of the mounting surface. Nylock nuts are provided to prevent the panel mounting screws from coming loose in operation.

Wire routing: Three copies of a "typical" wiring diagram are supplied for your convenience in wiring your car. One is bound into this manual for permanent reference, one is to be used as you install the wiring, and the last copy is to be used for checking your wiring work before applying power to the wiring and testing. It is suggested that you use a highlighter to mark each wire as it is routed, and then circle the ends of each wire after the terminations have been made.

As shipped, the wiring leaving the panel is grouped into three bundles. One bundle contains 24 wires, one contains 9 wires, and the third bundle consists of only one wire. All of the wires in the 9 wire bundle terminate under the hood or at the front of the car. All of the wires in the 24 wire bundle terminate inside the car, primarily under the dash, or on the transmission through the tunnel. The single wire bundle (yellow/red) is for the electric fuel pump, which will probably be mounted near the rear of the car. The remainder of the wiring is shipped in one large bundle of loose wires and in two small pre-wired harnesses.

Once the panel is solidly mounted, you may begin running the wires. If there is an existing hole of the proper size located near the panel, you may run the 9 wires through that hole, insuring that the wires are protected from chafing by a rubber grommet. If

there isn't a convenient hole, you'll have to drill one, using a hole saw. Again, be sure to protect the wires from chafing by the use of a grommet. After the grommet is installed, begin running the wires through to the under-hood area. It will probably be best to run the wires one at a time. If you are installing the optional ON-OFF-AUTO switch for the fan, be sure to leave enough slack on the black/green wire inside the car to allow for cutting to insert the switch in the circuit.

Once the wires are pulled through to the under-hood area, survey the area and select an appropriate routing path for the wires, making sure that this path keeps the wires away from any potential damage - heat, environment, or mechanical - and that sufficient attachment points are available to properly support the wiring, preventing movement. Lay the wires loosely along that path, and run each wire to its intended destination as shown on the included schematic. DO NOT cut any wire until the ALL the under-hood wire has been properly routed and the wiring bundle has been fastened in place. There will be more wire run to the front of the car than the wire in the 9 wire bundle, so wait until the total wire routing exercise is completed before cutting and terminating any wire. Leave the wiring you've just routed loosely in place until the remainder of the wire is installed.

Locate the alternator plug (with the short yellow and the long brown/yellow wires attached). If you are using a GM alternator, go ahead now and plug it in to the alternator, but loosely, as you'll be removing it when you test your wiring. If you are using another brand, cut the wires from the supplied alternator plug and re-terminate into the appropriate plug for the alternator you are using. Insert the correct plug into the alternator loosely, and run the brown/yellow wire back through the hole in the firewall with the other wires into the interior of the car. Terminate the short yellow wire on the appropriate alternator terminal, if required.

From the bundle of loose wires, pull the remaining wires that run to the under-hood area of the car. These wires will be, typically:

- green/red - left front turn signal
- green/white - right front turn signal
- red - front marker and parking lamps
- lt green/black - windshield washer
- white/brown - Low oil pressure switch
- white/red - starter solenoid
- black/purple (2 wires) - PDWA switch
- green/blue - water temperature sender
- yellow/black - oil pressure sender
- yellow/white - tachometer/coil connection

Go ahead and terminate these wires on the appropriate devices, and run the wires back into the car through the same grommet as the other wires. Or, alternatively, you may want to make more than one hole in the firewall and split the wires up into two or more bundles, running one of the bundles through each hole. NOTE: the green/red, green/white, and the red wires are supplied long enough to do both the front and the rear of the car. DO NOT cut these wires at this time.

Run the loose ends of the green/red and green/white wires to the rear of the car. Terminate these two wires at the rear, the green/red on the left turn signal, and the green/white on the right turn signal. Leave the excess wire laying under the dash for now.

Do the same thing with the red wire, but only terminate it on the first of the parking/marker lights you come to. This way, if your routing path used up all of the red wire, you can add wire later without having to splice. You should have plenty of red wire, so leave the excess coiled up under the dash along with the G/R and G/W wires. If you are not using bullet sleeve connectors for the rear light connections, don't make the red wire termination yet, as you will have to place two wires into the same connection, in a "daisy-chain" arrangement, to get to the other lights in the rear. In this case, just tape the end of the wire to the lamp connection temporarily.

Route the yellow/red wire for the fuel pump to the general location of the pump, but don't terminate it just yet.

Identify and remove the remaining wires from the large bundle that route to the back of the car. These wires are, typically:

- green/brown - brake lights
- green/purple - back-up lights
- green/black - fuel gauge sender
- purple - trunk lamp power

The other end of these wires should be placed under the dash, along with the 23 wire bundle from the panel. If you are installing rear speakers, this would be a good time to route these wires as well, but don't terminate them yet. The purple and the purple/white wires should now be routed from the courtesy lights, if any, to the under dash area. As you clean up the under dash wiring later, the purple/white wires will be routed to the door PIN switches. A short piece of purple/white wire will be needed to run from the trunk lamp to the trunk lid PIN switch.

You should now "tidy-up" the wiring under the hood and to the rear of the car, neatly bundling the wires in place with cable ties, and securing the wire bundles to sufficient supports such that the bundles won't move when the car is in motion, making sure the bundles clear any possible source of abrasion or cutting.

Now it's time to take care of the under dash wiring, which will be the hardest part of the job, as there is a large number of wires to deal with and very little space to deal with them in. If you can, you should take the dash out of the car with the instruments and warning lights installed, and wire them on your workbench. You won't be able to wire the inputs to the gauges and the warning lights from the senders yet, but you can pre-wire the illumination lights, instrument power, and ground connections.

If you are using the stock gauges, and the under dash wiring is not in bad shape, you may want to split open the factory wiring harness and remove and reuse those wires going to the gauges. This will greatly simplify things, as these wires will already have the lamp sockets attached, saving a lot of cutting and splicing. In this case, you will want to retain the red/white wires, the ground wires, and the light green/green wire from the voltage stabilizer.

If you are using aftermarket gauges, you won't be able to salvage the wiring, and you'll have to wire them from scratch, following the instructions provided by the manufacturer. With aftermarket gauges, you WON'T need the voltage stabilizer, and it must not be wired in. If you power the gauges from the voltage stabilizer, the gauges will rapidly swing from zero to the correct reading and back to zero.

While you have the dash out, you can run the rest of the wires under the dash, including the wires from the front and the rear of the car. Route the wires using the same procedures and precautions as for the other wiring, allowing the individual wires to peel out from the main bundle near their final destination.

Locate the small wiring harness with the five short wires and a plug on the end. This is the windshield wiper harness, which should now be plugged into the windshield wiper motor, and the five wires routed along with the rest of the wiring to a location near the wiper switch.

The final step under the dash, then, is to re-install the dash and make the final terminations of the under-dash wiring. After this is done, the rest of the wiring may be terminated. Once you're satisfied with the installation of the wiring, cover all exposed wiring under the hood with split loom wire covers or harness tape (available from the vendors listed on page 11) and prepare to test your wiring. See page 8 for testing instructions.

WIRING TECHNIQUES:

Crimping tools: Rather than using the typical auto parts store crimping tool for the standard terminations, I recommend going to Home Depot, Lowes, or similar, and buying a GB crimping tool as shown below. This tool has the advantage that it crimps "along" the wire, rather than "across the wire." This spreads the crimp over a larger area, and make a much better crimp. When crimping with this tool, make sure that the seam in the terminal is on the concave side of the jaws, rather than on the convex side. Otherwise, the tool will split the terminal, and make a very poor crimp. With this tool, you should use non-insulated terminals, solder them after crimping, and then slip heat shrink tubing over the terminal. If you can't find non-insulated terminals, pull the insulation off standard insulated terminals.

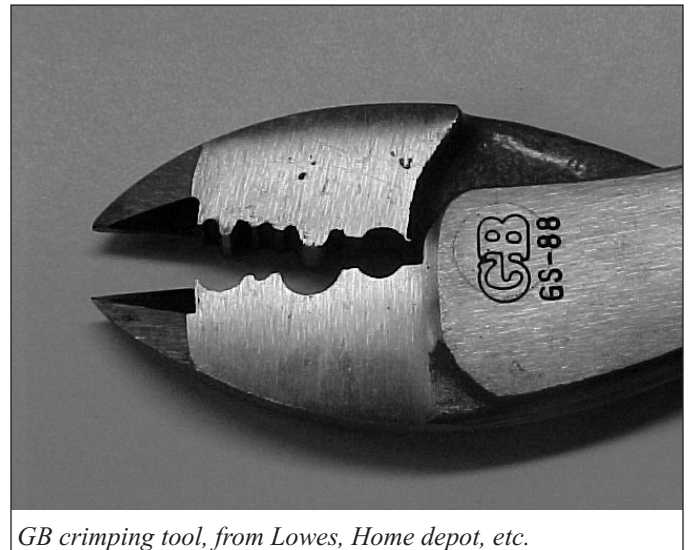

GB crimping tool, from Lowes, Home depot, etc.

You may prefer to use insulated terminals and standard crimping tools, without the added touch of soldering. For the most part, this is acceptable, and is much quicker than the technique just described. In my opinion, however, in addition to being not quite as good, it just screams *amateur!* This is, of course, a personal opinion, and you may well feel just the opposite.

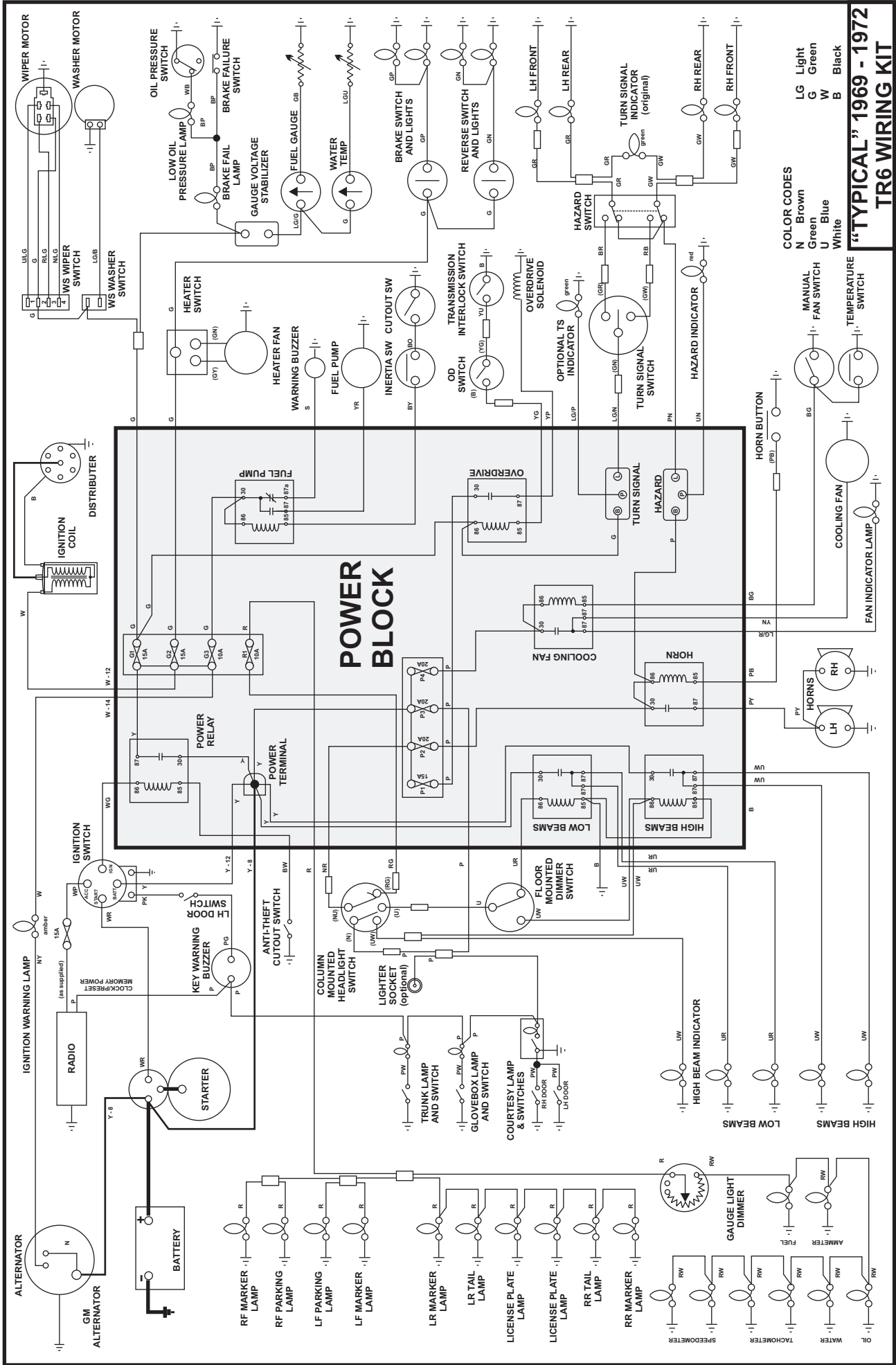

“TYPICAL” 1969 - 1972 TR6 WIRING KIT

COLOR CODES
 N Brown
 G Green
 U Blue
 White
 LG Light Green
 B Black

NOTE: three copies of this diagram, each printed full size on 11X17 paper, are included with the actual manual that ships with the kit.

Bullet/Sleeve connectors: The only reason for using connectors is to ease assembly - either on the factory assembly line or in your garage. Connectors are also the most common place for electrical problems, so you will be doing yourself a favor if you eliminate as many as you can, wiring directly to the components as much as possible. Still, there will be places where the standard British bullet/sleeve connectors will be needed.

British Wiring supplies two different kinds of bullets - those intended to be soldered, and those that may be soldered *or* crimped. I recommend using the latter type (supplied), and soldering them, rather than buying the solder only type. They just work better. When you solder, use a low temperature, rosin core solder, such as the 60/40 solder sold by Radio Shack. This is a small diameter solder, and works very well for automobile wiring purposes. **Do not** use acid core solder!

When soldering these bullets onto the wire, strip just enough of the wire so that the insulation is just inside the bullet when the tip of the wire is fully inserted. Hold the soldering gun next to the bullet while you try to feed the solder into the hole in the end of the bullet. As soon as the bullet is hot enough, the solder will start to flow and will be drawn into the bullet. Feed just enough solder to fill the bullet, but try not to feed enough that it wicks up the wire very far. A little bit of experimentation will show you just how much solder to feed. See photo below.

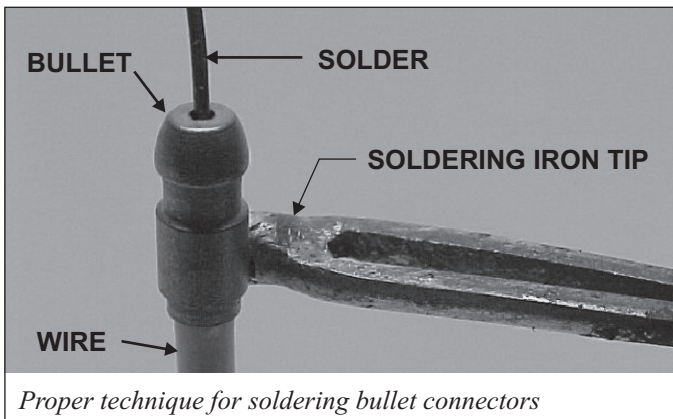

There is another option for installing bullet connectors, and that is to use a special crimping tool sold by British Wiring, just for bullets. It's a bit pricey, at around \$50.00, but it is **NICE!** I have one, and I will never solder bullets again.

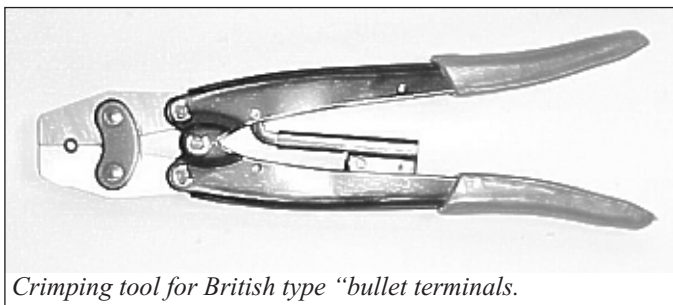

Headlight wiring: For maximum headlight brightness, you should eliminate **ALL** connections between the headlight relays and the headlight sockets. It takes a very small drop in voltage, as from connectors, etc, to reduce the brightness of the headlamps a

noticeable degree. Run the headlight wires directly into the headlight buckets, cover the wires with protective sleeving as they pass through holes in the buckets and the fenders to prevent abrasion, and crimp **AND** solder the wires to the socket terminals. If you should ever need to remove the wiring for some reason, you will have to either cut the wires just short of the sockets and replace the sockets when you're finished, or remove the terminals from the sockets as described earlier. Leave enough slack in the wires to allow for this. Wiring for the headlight sockets is shown on page 9.

To remove the wires from the headlight socket (or any similar sockets), just insert a small blade screwdriver or other sharp object into the socket as shown in the photo below to press the retaining clip down. Once the retaining clip is depressed, the terminal will slip out without any problem. When you re-insert the terminal, make sure the retaining clip has sprung back to its full retaining position. You may have to lightly pry the clip up before inserting to make sure it will hold properly in the socket.

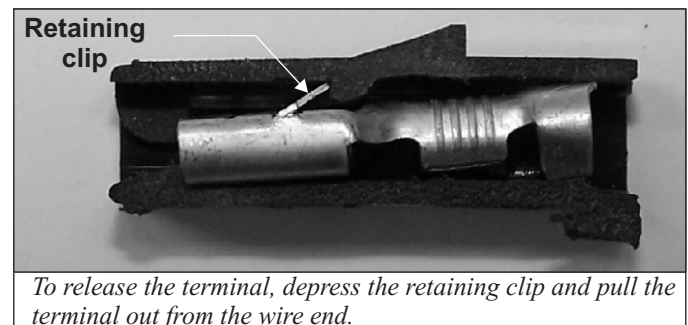

TESTING YOUR WIRING INSTALLATION:

After you've installed your wiring, it is a good idea to have a friend go over it one more time before you power up. Using the third copy of the schematic, including any modifications you've made to it, have him or her go back over everything, marking the wiring with a highlighter to indicate that each wire has indeed been run, and then circling each connection/termination as he/she verifies it.

Before applying power, make sure that **EVERYTHING** in the car is turned off, and the doors closed (to make sure the courtesy or the dome lights are not on). Remove the alternator plug from the alternator and place it where none of the plug wires can come into contact with ground. Remove the "courtesy lights" fuse (to remove power from the clock, radio, etc). After this is done, return the ground cable to the battery negative post, watching for sparks as you do. If you see sparks, you either have a load turned on, or there is a flaw in your wiring. If you have sparking, recheck your wiring. If not, connect and tighten the ground cable. Before doing anything else, walk around your car and look for smoke or heating of any wiring. If you didn't get any sparking when you connected the ground cable, you shouldn't have any problem, but check anyway.

Replace the fuse. At this time, all of the "hot all the time" loads have power. These loads include the headlights, parking lights, and all loads that are fed by a purple wire from the fuse block:

Optional fan switch:

The schematic diagram shows an optional ON-OFF-AUTO switch that may be desired (not supplied - you'll want to choose one that matches your dash decor). This switch provides the option of ensuring that the fan does NOT run under certain situations. For example, when you are working on the car under the hood, and you don't want to run the risk of injury from the fan starting unexpectedly, the ON-OFF-AUTO switch can be placed in the OFF position and the fan won't run (be sure to place that switch back in the ON or the AUTO position before driving the car to prevent the possibility of overheating). In the "ON" position, the fan runs all the time; In the "AUTO" position, the fan is turned on and off by the temperature switch.

Below the wiring diagram is a physical layout drawing. You can either use a SPDT or 1/2 of a DPDT switch, as long as the switch you use has a center-off position. Orientation is not important - see the switch diagrams below for details.

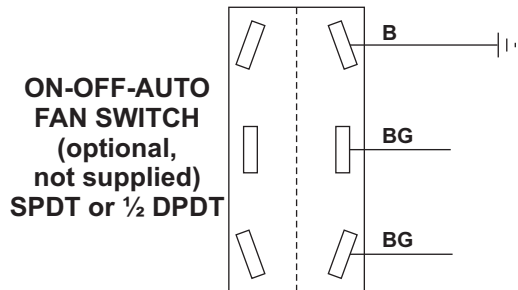
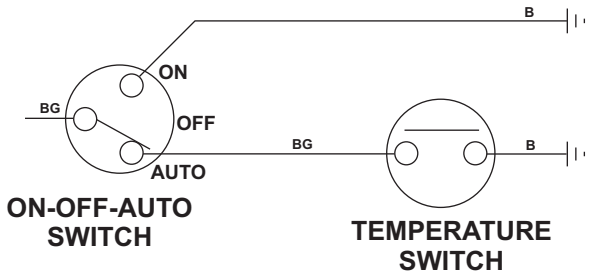

ON-OFF-AUTO FAN SWITCH (optional, not supplied) SPDT or 1/2 DPDT

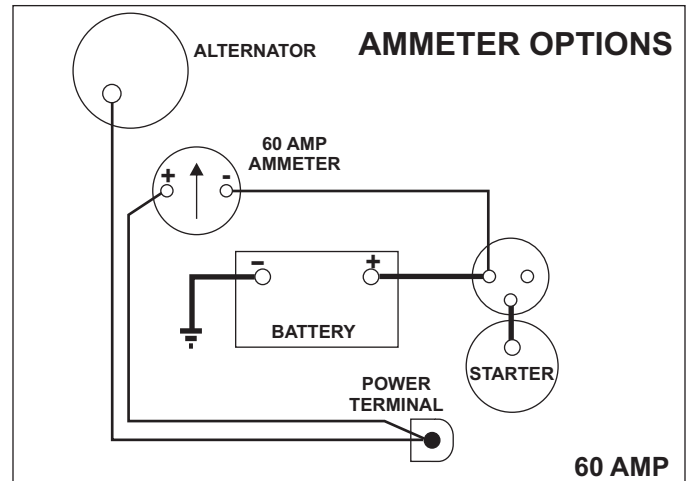

60 AMP STOCK

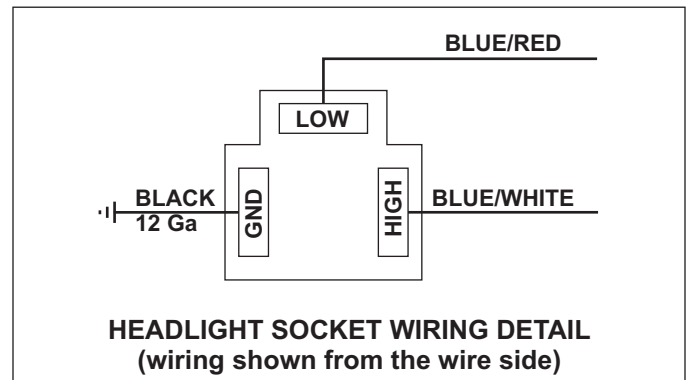
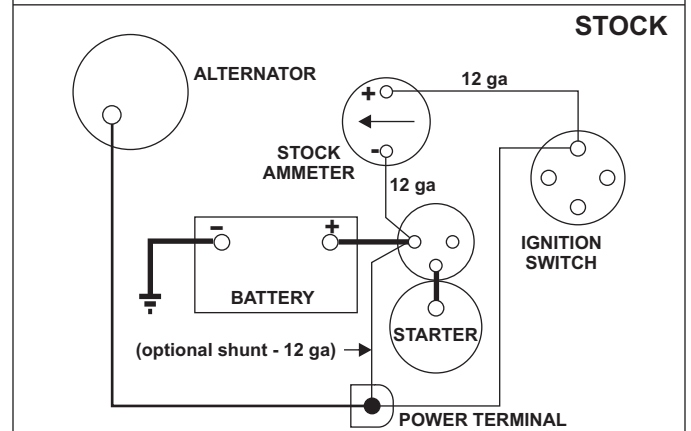

HEADLIGHT SOCKET WIRING DETAIL (wiring shown from the wire side)

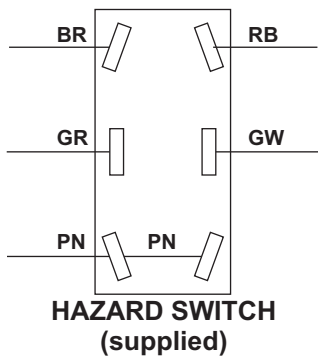

HAZARD SWITCH (supplied)

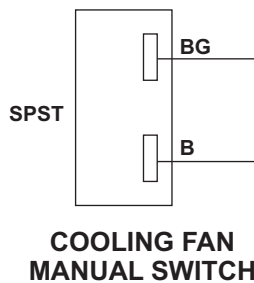

COOLING FAN MANUAL SWITCH

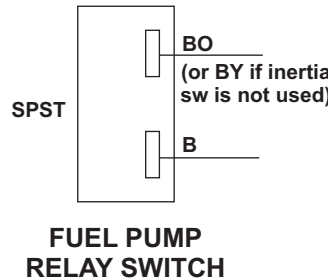

FUEL PUMP RELAY SWITCH

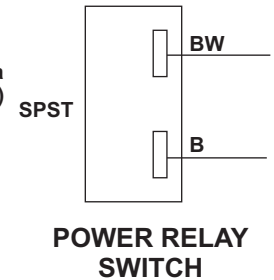

POWER RELAY SWITCH

(one switch is supplied, you choose where to apply it)

NOTE: Switches are shown from the back view. Orientation of the switches is not important. As long as your wiring looks like that above, it is OK. If the switch is orientated one way when you wire it,

"UP" on the switch handle will be "ON." Wired the other way, "UP" will be "OFF." Just rotate the switch to put the handle position for "ON" however you'd prefer it.

headlights	parking/marker lights
flash-to-pass headlight feature	courtesy/dome lights
cigar lighter	clock
radio memory	key warning buzzer
hazard flasher	horn
overdrive solenoid (see note below)	cooling fan

The first items to check will be your clock and your radio - they both should be operating now (the radio won't play yet, but the dial should be lit if you have one of the modern radios with a clock and memory). Next, check each of the remaining items above, one-by-one, and verify that they are all operable. Check the cooling fan by first operating the optional control switch to the ON position, if you've installed it. Next, place the switch in the AUTO position, and then ground the black/green wire at the thermostat switch. The fan should run. With the black/greenwire still grounded, operate the fan switch to the OFF position and verify that the fan turns off.

Now that you've verified the "always hot" circuits, it's time to test the "key switched" circuits, the circuits that are hot only when the key is in the "run" position. These circuits are:

radio	alternator drive
ignition	gauges
wipers/washer	turn signals
brake lights	back-up lights
fuel pump	dash warning lights
overdrive relay (see note below)	heater fan

Note: Power is available to the overdrive relay contacts at all times, but the relay will only operate when the ignition key is on. Power will be delivered to the overdrive solenoid only when the key is on AND the overdrive switch is on.

Pull the white wire from the ignition coil, and place it where it can't come into contact with ground (it will take a while to

complete the testing, and you don't want to keep your coil energized all that time) and pull the fuse for the fuel pump (you don't want it running during the testing either). Turn your ignition key to the "accessory" position and try your radio. If all is well, it should play. Turn the ignition switch to the "run" position. You should hear a relay click, and your gauges should come to life. If not, check to see that the power relay cutout switch is not in the OFF position. If flipping the switch causes the gauges to come to life, proceed with the testing. If not, check your wiring. Before proceeding further, make a visual and olfactory check.

If everything is in order, proceed with the testing by switching on and off the various loads listed above. Turn the key off and replace the fuel pump fuse. Turn the key back on, and you should either hear the fuel pump operate or the warning buzzer should sound. If you hear the warning buzzer, flip the cutout switch and make sure the inertia switch is reset. This should silence the buzzer, and you should now hear the pump run. With a voltmeter or a test lamp, verify that you have voltage at the white coil wire.

Switch the key off, replace the coil wire, and insert the alternator plug. Switch the key to the "run" position and check that the alternator warning light is on. Turn the switch to the "start" position. The engine should start, the alternator light should go out, and you deserve to take a short test drive (or sit back and have a cold one if the rest of the car is still unfinished).

Congratulations! That wasn't so hard, was it?

I believe I've covered everything you need to know to install this wiring panel in your car. If I've missed anything, or if you have further questions, feel free to contact me at:

tech@advanceautowire.com

SUGGESTED VENDORS

You shouldn't need to buy anything to complete your wiring, except for two switches, the inertia switch, and possibly a few minor pieces of hardware. However, if you need extras, or if you should make additions/modifications to the design, you should be able to get whatever you need from one of the vendors listed below.

American Autowire Systems
 150 Heller Place, #17 West
 Bellmawr, NJ 08031
 1-800-482-9473
 www.americanautowire.com

Ron Francis Wire Works
 167 Keystone Road
 Chester, PA 19013
 1-800-292-1940
 www.wire-works.com

British Wiring
 PO Box 185
 617 Walnut Street
 Bally, PA 19503
 1-620-845-3518
 www.britishwiring.com

Moss Motors
 440 Rutherford Street
 Goleta, CA 93116
 1-800-667-7872
 www.mossmotors.com

Waytek, Inc
 PO Box 690
 Chanhassen, MN 55317-0690
 1-800-328 2724
 www.waytekwire.com

MAD Enterprises
 PO Box 675
 Springville, CA 93265
 1-559-539-7127
 www.madelectrical.com

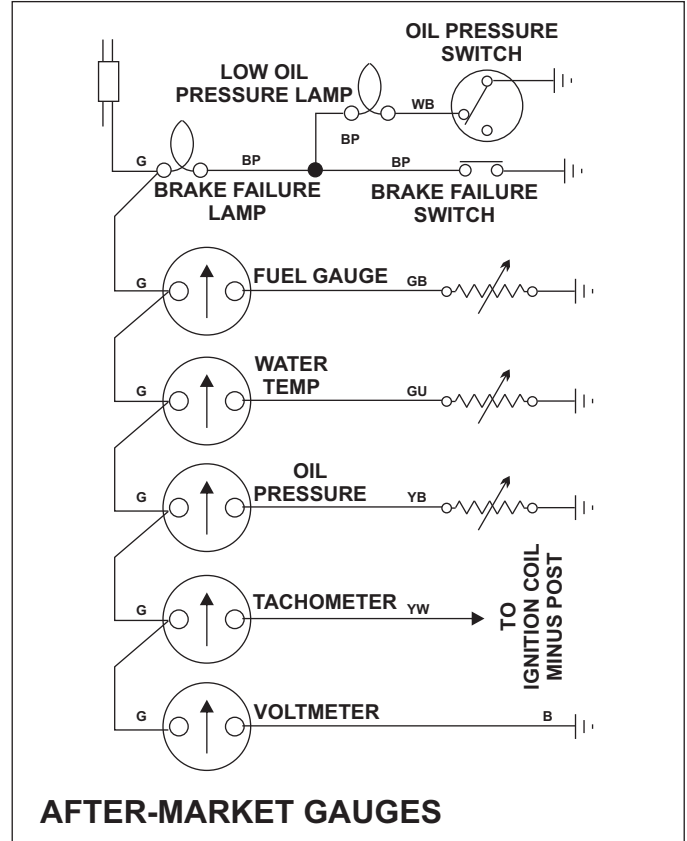

AFTER-MARKET GAUGES

POWER RELAY 4-pin SPST BOSCH 0 332 019 103	FUEL PUMP RELAY 5-pin SPDT BOSCH 0 332 209 151	COOLING FAN RELAY 5-pin SPST BOSCH 0 332 019 151	HORN RELAY 4-pin SPST BOSCH 0 332 019 103	LOW BEAM RELAY 5-pin SPST BOSCH 0 332 019 151	HIGH BEAM RELAY 5-pin SPST BOSCH 0 332 019 151
--	--	--	---	---	--

NOTE: Bosch relay part numbers are for replacements only - relays supplied may be a different brand and/or part number.

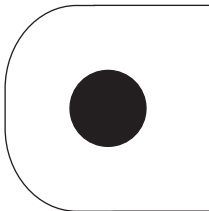

POWER TERMINAL

HAZARD FLASHER Tridon 552 (short can)	OVERDRIVE RELAY 4-pin SPST BOSCH 0 332 019 103	TURN SIGNAL FLASHER Tridon 552 (short can)
--	--	---

15A OVERDRIVE SOLENOID	20A HORNS HAZARDS	20A COURTEAY LIGHTS RADIO MEMORY CIGAR LIGHTER	20A COOLING FAN
---------------------------	----------------------	---	--------------------

15A WW WIPER GAUGES T-SIGNALS OD RELAY	15A HEATER REVERSE LITES BRAKE LITES	10A FUEL PUMP	10A PARKING LIGHTS
---	---	------------------	-----------------------

COLOR CODE USAGE 1969 - 1972 TR6

WIRE COLOR		FUNCTION	installed	tested
black	B	ground		
black/green	BG	cooling fan switch to relay		
black/orange	BO	fuel pump cutout switch		
black/purple	BP	brake failure indicating switch		
black/red	BR	turn signal switch to hazard switch LH		
black/white	BW	ignition relay cutout switch		
black/yellow	BY	inertia switch to fuel pump relay		
blue/black	UB	handbrake lamp		
blue	U	headlight switch to dimmer switch		
blue/brown	UN	hazard indicator		
blue/lt green	U/LG	windshield wiper switch to motor		
blue/red	UR	low beams		
blue/white	UW	high beams		
brown/lt green	N/LG	windshield wiper switch to motor		
brown/red	NR	power to headlight switch		
brown/yellow	NY	alternator warning light		
green/black	GB	fuel gauge sender		
green/blue	GU	temperature gauge sender		
green/brown	GN	reverse lights/heater power from heater switch		
green	G	switched power - hot only when the ignition key is on		
green/purple	GP	brake lights		
green/red	GR	LH turn signals		
green/white	GW	RH turn signals		
green/yellow	GY	heater power from heater switch		
lt green/black	LG/B	windshield washer		
lt green/brown	LG/N	turn signal flasher to turn signal switch		
lt green/green	LG/G	voltage stabilizer to gauges		
lt green.purple	LG/P	turn signal indicator		
lt green/red	LG/R	fan indicator		
purple/black	PB	horn button		
purple/brown	PN	hazard flasher to hazard switch		
purple/green	PG	ignition key warning buzzer		
purple/pink	PK	ignition key warning switch		
purple	P	unswitched power - hot with ignition key on or off		
purple/white	PW	courtesy light grounding switches		
purple/yellow	PY	power to horns from horn relay		
red/black	RB	turn signal switch to hazard switch, RH		
red/green	RG	power from headlight switch to parking lamp fuse		
red/lt green	R/LG	windshield wiper switch to motor		
red	R	parking lights and power to gauge lamp dimmer		
red/white	RW	gauge lights		
slate	S	fuel pump warning		
white/black	WB	distributor to coil/oil pressure switch to low oil indicating lamp		
white/green	WG	ignition switch to power relay		
white/purple	WP	radio		
white/red	WR	power from igtion switch to starter solenoid		
white	W	ignition power to coil and alternator warning lamp		
yellow/blue	YU	overdrive switch to transmission interlock switch		
yellow/brown	YN	power to fan from fan relay		
yellow/green	YG	overdrive switch to transmission interlock switch		
yellow/purple	YP	power feed to overdrive switch from fuse block		
yellow/red	YR	power to fuel pump from fuel pump relay		
yellow	Y	primary power feed		

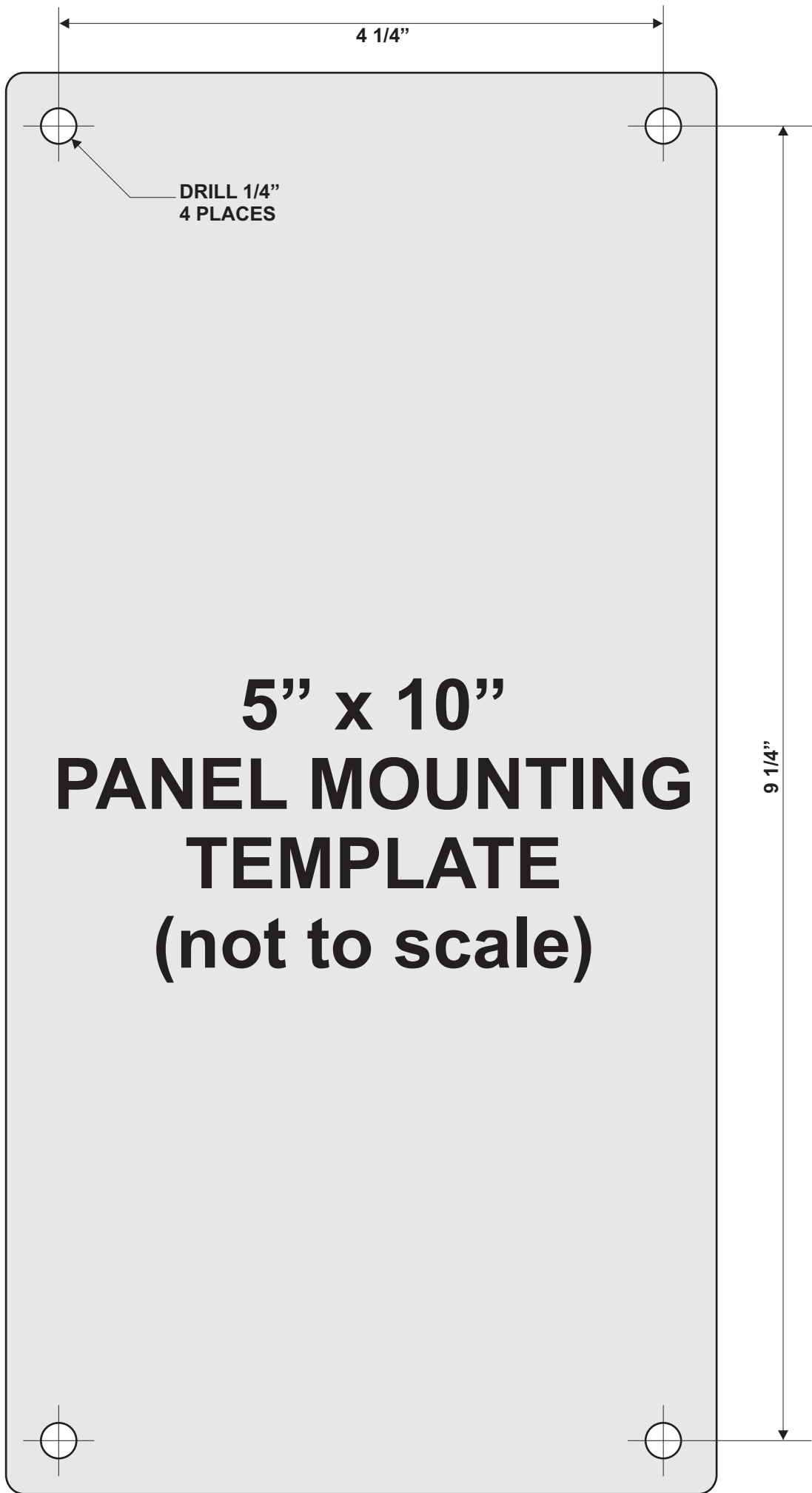

4 1/4"

DRILL 1/4"
4 PLACES

5" x 10"
PANEL MOUNTING
TEMPLATE
(not to scale)

9 1/4"